

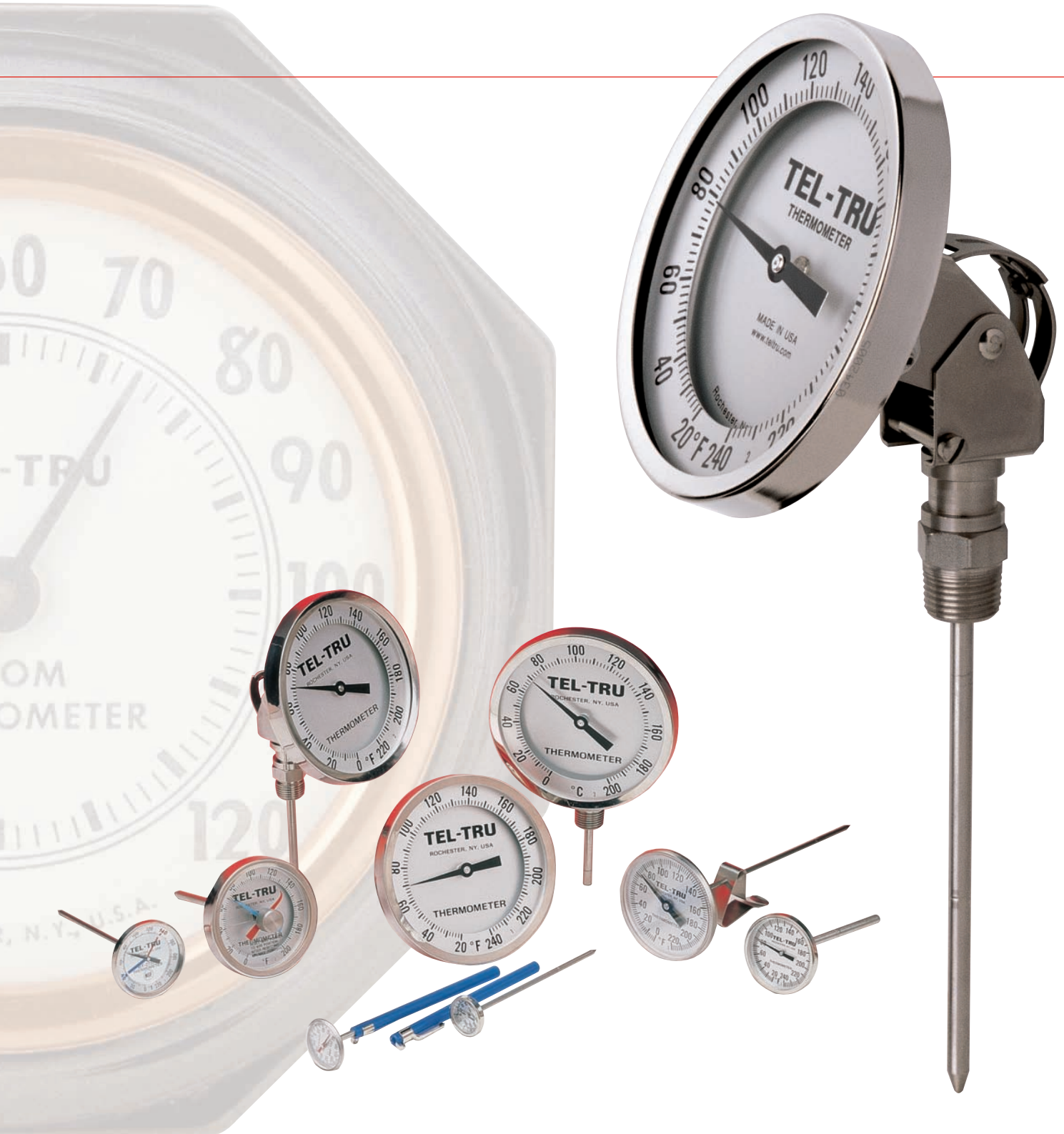

TEL-TRU® MANUFACTURING COMPANY

BIMETAL THERMOMETERS



World-Class Thermometers Since 1916

www.teltru.com

Tel-Tru® Manufacturing Company
World-Class Thermometers

We manufacture thermometers — but we sell service, reliability, product quality and performance, and our experience working with customers to solve temperature measurement and monitoring application problems.

Since my grandfather Harry Germanow started making household products in 1916 to today's temperature and pressure instruments, serving industrial, commercial, and OEM markets, our tradition has been to meet or exceed customer expectations.

Our goal is total customer satisfaction through *World-Class* manufacturing, service and support.

Tel-Tru's *World-Class* philosophy encompasses a customer-centric staff and culture supported by state-of-the-art equipment and manufacturing processes.

In our Rochester, NY factory, we continually make investments to expand and improve our capabilities and our capacity to produce bimetal thermometers that are the world-standard for quality workmanship and accuracy.

This product brochure provides you with a view of Tel-Tru quality as well as all the information you need to select the bimetal thermometer most appropriate for your application.

We look forward to providing you with a *World-Class* experience — the tradition continues!

Andy Germanow
President



Tel-Tru® Manufacturing Company

408 St. Paul St., Rochester, New York 14605 USA

Phone: 585.232.1440 • 800.232.5335 • Fax: 585.232.3857 • E-mail: info@teltru.com • Web: www.teltru.com

Table of Contents

QUALITY AND PERFORMANCE FEATURES

Bimetal Thermometers Cross Section of Quality page 2

SELECTING YOUR THERMOMETER

Considerations When Selecting Bimetal Thermometers..... page 4

Safety and Application Considerations..... page 4

Recommendations for Checking the Calibration of Bimetal Thermometer..... page 5

Warranty page 5

How to Order page 6

Standard Features and Available Options..... page 7

PRODUCTS

3", 4" and 5" Adjustable Angle Industrial Thermometers page 8

3", 4" and 5" Back Connected Industrial Thermometers page 10

3", 4" and 5" Bottom Connected Industrial Thermometers..... page 12

1³/₄" and 2" Back Connected Industrial Thermometers page 14

1³/₄", 2" and 3" Laboratory Testing and General Purpose Thermometers..... page 16

1" and 1³/₈" Testing and Spot Checking Thermometers page 18

OPTIONS AND ACCESSORIES

Connections, Fittings, Lenses, Dials, Tagging and Mounting Flanges..... page 20

Thermowell Adapter kit page 20

THERMOWELLS

Threaded, Flanged, Welded, Sanitary and Van Stone..... page 21

SPECIAL CONFIGURATION AND APPLICATION THERMOMETERS

OEM Thermometers page 22

Heavy Duty Marine Thermometers page 22

Silicone Filled Thermometers page 23

Thermometers with Heavy Duty Pointed Stem and Detachable Handle page 23

Sanitary Bimetal Thermometers page 23

Glow Dial and Reflective Thermometers..... page 24

Minimum and Maximum Thermometers page 24

Food Service Thermometers page 25

Check-Set™ Thermometer Calibrators page 25

TEL-TRU BIMETAL THERMOMETERS ARE MANUFACTURED IN THE USA.

Tel-Tru® Manufacturing Company

World-Class Thermometers

We manufacture thermometers - but we sell service, reliability, product quality and performance.

► QUALITY AND PERFORMANCE FEATURES:

★ CASE AND BEZEL

- 304 stainless steel standard
- 316 stainless steel optional
- All external parts corrosion resistant to most chemicals
- Parts designed for maximum strength to meet requirements of heavy duty industrial applications
- Manufactured with precision tooling on modern OSHA approved stamping equipment
- Statistical Process Control QA methods used to assure component quality and process consistency
- Polished finish identifies Tel-Tru quality
- Cases may be silicone filled for additional dampening of extreme vibration, or to assure consistent performance in low process temperature/high environmental humidity applications

★ LENS

- Extra heavy duty instrument glass standard
- Shatterproof glass, tempered glass, and plastics optional

★ POINTER

- Black painted aluminum
- Balanced and precisely assembled to bimetal coil stem
- Direct transfer of coil movement to temperature displayed on dial

★ DATE STAMPING

- Available for QA tracking of industrial thermometers

★ HERMETIC SEAL

- Case/Bezel assembly is a precision interference fit
- Silicone gasket provides dustproof and leakproof seal
- Welded construction-Unique 360° TIG weld joins case, stem and threaded connection
- Testing conforms with ASME B40.3 procedures

★ THREADED CONNECTION

- 304 stainless steel standard
- 316 stainless steel optional
- Precision manufactured on Tel-Tru CNC machines
- Statistical Process Control QA methods used to assure component quality and process consistency

★ EXTERNAL RESET

- Calibration adjustment using an Allen wrench discourages inadvertent tampering
- Stainless steel pinion is sealed with a silicone "O" ring to maintain integrity of hermetic seal
- Pinion works with gear teeth cut and formed in dial
- Models without reset are available

★ DIAL

- True anti-parallax dial on 3", 4" 5" models
- Graduations on dial ring are on the same plane as the pointer tip minimizing reading error
- Concave design of dial ring enhances readability
- White appearing .032" anodized aluminum
- Graduations for each temperature range are calculated to match deflection data of bimetallic material
- Large easy to read black numerals and graduations are printed on precision pad printing equipment in our factory

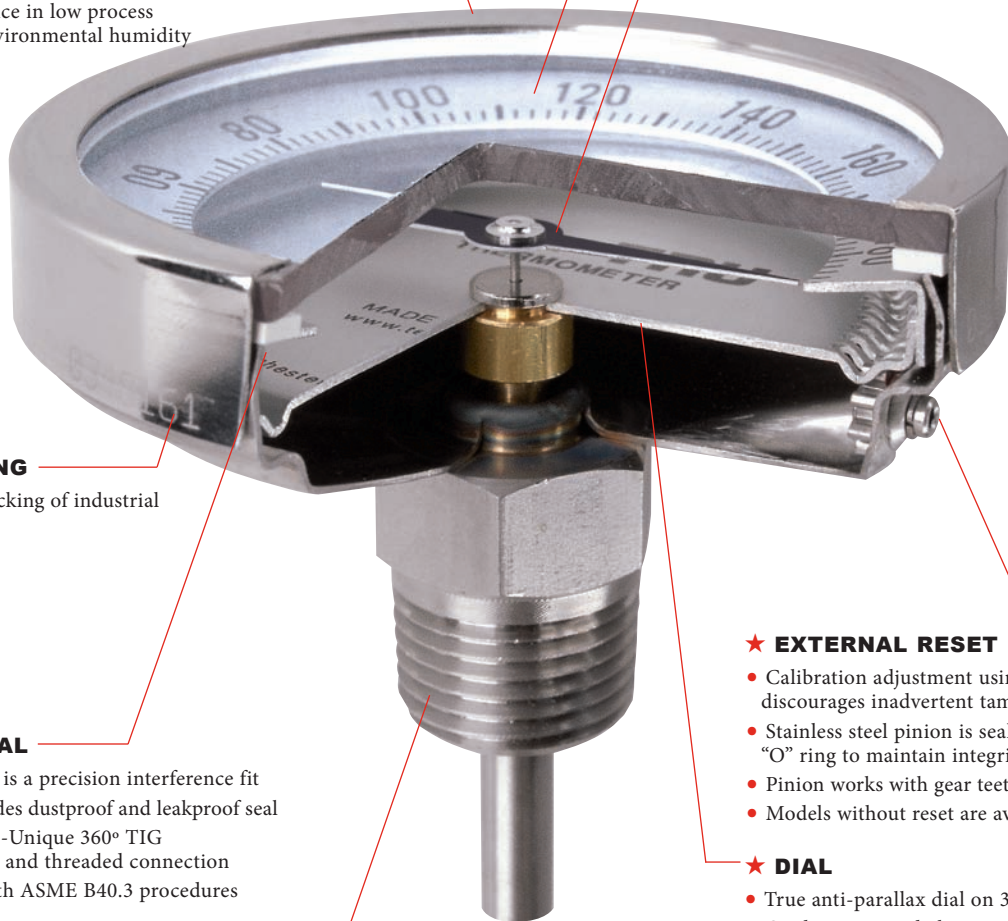



Tel-Tru® Manufacturing Company

408 St. Paul St., Rochester, New York 14605 USA

Phone: 585.232.1440 • 800.232.5335 • Fax: 585.232.3857 • E-mail: info@teltru.com • Web: www.teltru.com

★ BIMETAL COIL

- Super sensitive bimetallic helix coil
- Fabricated to tight tolerances
- Heat treated for stress relief
- Silicone coated to minimize pointer vibration and maximize heat transfer and response time
- Angular deflection of each coil is tested for perfect match with dial graduation layouts in precision calibration baths designed and built by Tel-Tru with accuracy to $\pm\frac{1}{16}^{\circ}\text{F}$

★ ACCURACY

- Per ASME B40.3 Grade A $\pm 1\%$ full span is guaranteed
- Calibration is to standards traceable to National Institute of Standards and Testing (NIST)
- Tel-Tru methods:
 - * Most careful and precise in the industry
 - * Produces typical accuracy better than ASME B40.3 Grade AA (1% - 1/2% - 1%) full span

★ BIMETAL BUSHING

- Pressed into groove on stem
- Centers coil in stem
- 302 stainless steel stem wire goes through center of bushing connecting bimetal element to pointer, minimizes coil touching tube wall
- Centering bearings are used at regular intervals on long stem thermometers

★ TEMPERATURE RANGES

- 20 Standard Fahrenheit ranges from -100° to 1000°
- 20 Standard Celsius ranges from -75° to 550°
- 13 Standard Dual scale ranges
- Availability of over 120 ranges developed, may vary by dial size

★ OVER TEMPERATURE LIMITS

- Up to 250°F 100%
- 250°F to 550°F 50%
- 550°F to 1000°F 800°F for continuous use, intermittent use over 800°F

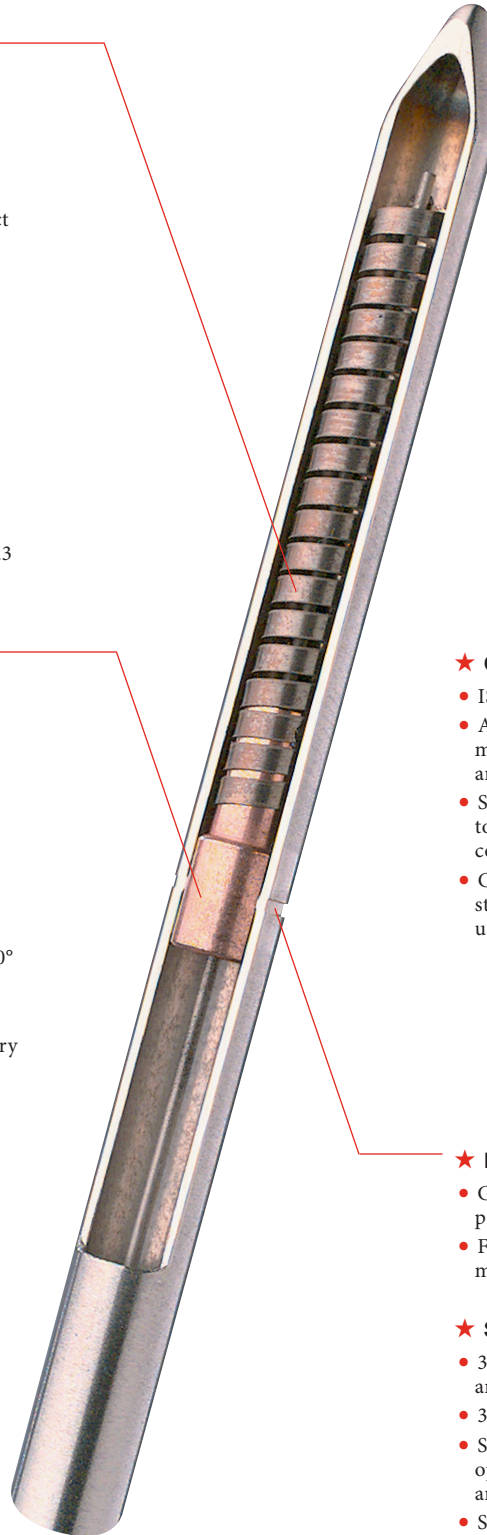

★ QUALITY SYSTEM

- ISO 9000 comparable
- Assures that all materials, methods and processes meet Tel-Tru's highest standards for form, fit, and function
- Statistical Process Control QA methods used to assure component quality and process consistency
- Calibration lab for NIST traceable verification of all standard thermometers and measuring instruments used in manufacturing process

★ IMMERSION:

- Groove around stem shows minimum immersion point on each thermometer
- For most accurate reading sensitive portion of stem must be completely immersed

★ STEM

- 304 Stainless steel tubing is welded/drawn and fabricated to exacting tolerances
- 316 stainless steel optional
- Standard stem diameter is $.250''$ (6.35mm) – options include $.375''$ (9.52mm), $.236''$ (6mm) and $.315''$ (8mm)
- Stem lengths available from $2\frac{1}{2}''$ to 120"
- Tip is welded and finished for hermetic seal and unique look

Selecting Your Thermometer

➤ CONSIDERATIONS WHEN SELECTING BIMETAL THERMOMETERS:

MATERIALS

- Application? Continuous process flow, static tank, or laboratory testing etc.
- Environmental conditions? Ambient temperature, humidity, or corrosive atmosphere (salt spray etc.)
- Process conditions? Pressure, temperature, media viscosity, rate of flow, and possible vibration
- Wetted material of thermometer compatible with measured medium?
- Window material?

MODEL TYPE

- Dial size?
- Location of fitting connection for maximum readability when thermometer is installed in system– Back, adjustable angle, bottom, top, right side or left side connection location?
- Fitting thread size and type?

STEM

- Pipe size or depth of tank?
- Immersion length required?
- Stem length?
- Stem diameter?

TEMPERATURE RANGE

- Operating temperature of process? High and low
- Overall temperature range required? High and low
- Over-Range possibilities? Minimum and maximum
- Accuracy required?
- External reset required?
- Scale - °F, °C or dual?
- Bimetal thermometers should not be used continuously over 800°F (450°C)

OPTIONS AND ACCESSORIES

- Thermowell?
- Silicone filling?
- Minimum and/or maximum indicating pointers?
- Custom or special dial marking or colors?
- Sliding compression fittings– male or female?
- Thread size adapters?
- Project tagging?

➤ SAFETY AND APPLICATION CONSIDERATIONS:

- Use of a thermowell is recommended for pressure, corrosive fluid or high velocity applications.
- Use of a thermowell allows removal of thermometer for calibration check or interchange of instruments without shutting down the process.
- Install thermometers in locations that minimize injury or damage in the event of an accidental breach of stem/ thermowell combination.
- Cases may be silicone filled for additional dampening of extreme vibration, or to assure consistent performance in low process temperature/high environmental humidity applications.
- Silicone filled thermometers are limited for use with process temperatures ranging from a minimum of -50°F (-45°C) to a maximum of 500°F (260°C).
- Use of silicone fill should be avoided where strong oxidizing agents such as oxygen, chlorine, nitric acid, and hydrogen peroxide are present.
- Bimetal thermometers should not be exposed continuously to process temperatures over 800° F (425° C) to avoid damaging the bimetal element.
- For 2/8" stem industrial thermometers:
 - The connection nut should be immersed or in contact with the process media for most accurate reading.
 - When used with limited space thermowells some reading error may be noticed depending on process and ambient temperatures.
- Operating conditions – It is recommended the temperature of the thermometer head not exceed:
 - 200°F (93°C) for glass lenses
 - 150°F (65°C) for plastic lenses
 - 150°F (65°C) for silicone filled thermometers
- Optional lens materials:
 - Acrylic plastic
 - Fair chemical resistance but low temperature limit
 - Polycarbonate plastic
 - Higher temperature limit than acrylic but poor chemical resistance
 - Shatterproof laminated safety glass
 - High corrosion resistance
 - Plastic laminate between two pieces of glass will hold fragments in place if broken but laminate will start to deteriorate above 200°F
 - Tempered glass
 - Improved to withstand a broad range of temperature changes
 - More impact resistant than regular glass



Tel-Tru® Manufacturing Company

408 St. Paul St., Rochester, New York 14605 USA

Phone: 585.232.1440 • 800.232.5335 • Fax: 585.232.3857 • E-mail: info@teltru.com • Web: www.teltru.com

► **RECOMMENDATIONS FOR CHECKING THE CALIBRATION OF BIMETAL THERMOMETERS:**

Use of a **MASTER THERMOMETER**, at least as accurate as a bimetal thermometer, is recommended for making comparisons. For best results, use a **precision ASTM** type mercury-in-glass thermometer certified directly traceable to NIST.

Immersion of the bimetal thermometer stem into the medium must be at least up to the groove on the stem to **assure that the entire bimetal coil is immersed**.

- In some short stem Tel-Tru industrial thermometers the groove may be hidden by the threaded connection; the entire stem and thread should be immersed in this case.

CALIBRATION TEST EQUIPMENT CONSIDERATIONS:

Check the stability and accuracy specifications of this instrumentation, and cross-check the read-outs with NIST traceable mercury in glass thermometers. Make certain the test instrument is stabilized at the reading point as initial insertion of thermometer stem into bath/dry block can sometimes have a short-term affect on test device stability.

- Take reading of Bimetal Thermometer when the pointer has stabilized and stopped moving. Typical immersion time may vary from approximately 1 to 3 minutes depending on type of thermometer, temperature point and calibration test equipment used.

Use of a laboratory grade **CONSTANT TEMPERATURE BATH**, with **agitation** to provide uniform temperature throughout, is recommended.

- Controls and read-out (if provided) should be properly calibrated and at least as accurate as the bimetal thermometer being tested.
- Confirm upper and lower limits of bath operating range as accuracy and stability may not be as consistent at those points.

If using a **DRY BLOCK** calibration device consider:

- The hole into which thermometer is inserted should allow for minimal air space around stem.
- The temperature profile of the “hole” may affect the reading of the tested bimetal thermometer— if the heat source is only at the bottom of hole or is not uniform over the length of the bimetal coil. This is compounded with short stem thermometers.

Tel-Tru Check-Set™ Temperature Calibrators are recommended for verification of thermometer accuracy in food safety and food service **HACCP** (Hazardous Analysis Critical Control Points) programs.

★ Please call, fax or e-mail Tel-Tru if you have any questions, require review of process or need assistance. ★

► **EIGHT YEAR WARRANTY**

There is no better guarantee of quality bimetallic dial thermometers than the name Tel-Tru Manufacturing Company. And now, no guarantee lasts longer. Tel-Tru models AA375R, AA475R, AA575R, BC350R, BC450R, BC550R, GT300R, GT400R, and GT500R carry an EIGHT YEAR guarantee. It's simple! If the thermometer covered fails and you have not misused your Tel-Tru Thermometer, simply call us at 1-800-232-5335. We warrant certain designated instruments (AA375R, AA475R, AA575R, BC350R, BC450R, BC550R, GT300R, GT400R, and GT500R) manufactured and sold by us to be free from defects in material and workmanship under normal use and service. This warranty shall be null and void if the thermometer is exposed or subjected to: (1) corrosive chemicals, either environmentally or through manufacturing processes; (2) temperatures in excess of the rated over-temperature limit; or (3) any application which subjects the thermometer to excessive vibration or causes violation of the stem or case enclosure. Our obligation under this warranty shall be limited to the repair or exchange of any thermometer which shall be returned to our factory, transportation charges prepaid, within eight (8) years of the date of purchase, and which our examination shall disclose to be defective due to workmanship or material. This warranty is expressly in lieu of all other warranties expressed or implied (including any warranty of merchantability and fitness for a particular purpose), and of all other obligations or liabilities on our part for damages, including but not limited to consequential damages, arising out of the use or misuse of this thermometer, and we neither assume, or authorize any other person to assume for use, any other liability in connection with the sale of this thermometer or any part thereof. Warranty on all other models is one year under the same conditions as noted above.

How to Order

► HOW TO ORDER:

EXAMPLE

MODEL CODE	STEM LENGTH	RANGE
3410	04	59

- 1) Model Code _____
- 2) Connection Size and Thread Type _____
- 3) Stem Length _____
- 4) Temperature Range _____
- 5) *State Options and Accessories When Required – See Standard Features and Options Table*

► MODEL CODES, CONNECTIONS SIZE AND THREAD TYPE

.250" Diameter Stems– Industrial					
Dial Size	Model	NPT	Lens	Con. Loc.	CODE
2" (51mm)	LN250	1/4"	Glass	Back	3110
	LN250R	1/4"	Glass	Back	3210
3" (80mm)	GT300	1/2"	Glass	Back	3310
	GT300R	1/2"	Glass	Back	3410
	MX325R	1/2"	Glass	Back	3610
	MM325R	1/2"	Glass	Back	5010
	BC350R	1/2"	Glass	Bottom	3910
	AA375R	1/2"	Glass	Adjustable	4110
4" (100mm)	GT400	1/2"	Glass	Back	4510
	GT400R	1/2"	Glass	Back	4810
	BC450R	1/2"	Glass	Bottom	4610
	AA475R	1/2"	Glass	Adjustable	4710
5" (128mm)	GT500	1/2"	Glass	Back	3710
	GT500R	1/2"	Glass	Back	3810
	MX525R	1/2"	Glass	Back	5310
	MM525R	1/2"	Glass	Back	5410
	BC550R	1/2"	Glass	Bottom	4010
	AA575R	1/2"	Glass	Adjustable	4210

.150" Diameter Stems– Industrial					
Dial Size	Model	NPT	Lens	Con. Loc.	CODE
1 3/4" (44mm)	GT200	1/8"	Glass	Back	1910
	GT200	1/4"	Glass	Back	2010
2" (51mm)	GT225	1/8"	Glass	Back	4910
	GT225	1/4"	Glass	Back	491A

.150" Diameter Stems– Pocket/Laboratory					
Dial Size	Model	NPT	Lens	Con. Loc.	CODE
1" (25mm)	PT50R	N/A	Plycrb.	Back	1210
	PT50	N/A	Plycrb.	Back	1110
	AD10R	N/A	Plycrb.	Back	1219
1 3/8" (36mm)	AD44R	N/A	Plycrb.	Back	4419
1 3/4" (44mm)	MT39	N/A	Glass	Back	1310
	MT39R	N/A	Glass	Back	1410
	GT100R	N/A	Glass	Back	1610
2" (51mm)	LT225R	N/A	Glass	Back	2310
	LT225	N/A	Glass	Back	2210
3" (80mm)	LT330R	N/A	Plycrb.	Back	2819

► STEM LENGTHS

Stem Lengths	Code
-2 1/2" (63mm)	02
4" (100mm)	04
* 5" (128mm)	05
6" (152mm)	06
* 8" (203mm)	08
9" (229mm)	09
12" (305mm)	12
15" (381mm)	15
18" (457mm)	18
24" (610mm)	24

* Laboratory and test thermometers .150" only

► STANDARD TEMPERATURE RANGES

Fahrenheit	Code	Celsius	Code
-100/100	51	-75/175	87
-50/120	52	-70/70	EA
-40/160	53	-50/100	71
0/140	54	-50/25	72
0/180	55	-50/50	73
0/200	50	-40/70	84
0/220	56	-20/120	86
0/250	67	-10/110	74
0/300	57	0/50	75
0/500	58	0/60	95
20/240	59	0/80	EI
25/125	60	0/100	76
50/250	61	0/150	77
50/300	62	0/200	78
50/400	63	0/250	79
50/500	64	0/300	80
50/550	68	0/400	81
100/800	44	0/450	90
150/750	65	100/400	82
200/1000	66	100/550	83

DUAL RANGES

Fahrenheit	Celsius	Code
-100/100	-75/40	01
-40/160	-40/70	02
0/140	-18/60	13
0/180	-18/82	03
0/220	-10/100	04
0/250	-20/120	14
20/240	-10/110	05
25/125	0/50	06
50/300	10/150	07
50/400	0/200	08
50/500	0/250	09
150/750	50/400	10
200/1000	100/550	11

Availability of temperature ranges varies by model. Dial size must be 1-3/8" or larger.



Tel-Tru® Manufacturing Company

408 St. Paul St., Rochester, New York 14605 USA

Phone: 585.232.1440 • 800.232.5335 • Fax: 585.232.3857 • E-mail: info@teltru.com • Web: www.teltru.com

STANDARD FEATURES AND AVAILABLE OPTIONS

Head Dia. Model	Laboratory and Testing Thermometers									Industrial		Industrial Thermometers						
	1"			1 ³ / ₈ "	1 ³ / ₄ "		2"		3"	1 ³ / ₄ "	2"	2"	3", 4" and 5"					
	PT50 (1110)	PT50R (1210)	AD10R (1219)	AD44R (4419)	GT100 (1510)	GT100R (1610)	LT225 (2210)	LT225R (2310)	LT330R (2819)	GT200	GT225 (4910)	LN250 (3110)	AAR (3" 4110)	BCR (3" 3910)	GT (3" 3310)	GTR (3" 3410)	MMR (3" 5010)	MXR (3" 3610)
Glass	†	†			✓	✓	✓	✓		✓	✓	✓	✓	✓	✓	✓	✓	✓
Glass, Shatterproof													○	○	○	○		
Glass, Tempered					○	○	○	○		○	○	○	○	○	○	○		
Plastic, Acrylic							○	○			○	○	○	○	○	○		○
Plastic, Polycarbonate	†	†	✓	✓	○	○	○	○	✓	○	○	○	○	○	○	○		
.140"	○	○	○	○	○	○	○	○	○	○	○							
.150"	✓	✓	✓	✓	✓	✓	✓	✓	✓	✓	✓							
.187"							○	○	○									
.236" (6mm)													○	○	○	○	○	○
.250"												✓	✓	✓	✓	✓	✓	✓
.315" (8mm)													○	○	○	○	○	○
.375"												○	○	○	○	○	○	○
Bushing, Plain	✓				✓		✓					○	○	○	○	○	○	○
Bushing, 1/4" - 20	○				○		○											
Bushing, 1/4" - 28	○				○		○											
Bushing, 3/8" - 24	○				○													
Nut, Recalibrating		✓	✓	✓			✓	✓										
Nut, 1/16" NPT	○									○								
Nut, 1/8" NPT	○									✓(1910)	○	○						
Nut, 1/4" NPT	○									✓(2010)	✓	✓	○	○	○	○	○	○
Nut, 1/4" BSPT	○									○		○(3210)	○	○	○	○	○	○
Nut, 3/8" NPT	○									✓(2110)	○	○	○	○	○	○	○	○
Nut, 3/8" BSPT												○	○	○	○	○	○	○
Nut, 1/2" NPT	○									○	○	○	✓	✓	✓	✓	✓	✓
Nut, 1/2" BSPT												○(3110)	○	○	○	○	○	○
Union, 1/2" NPT													○	○	○	○	○	○
Other Connections	Other connection fittings available upon request.																	
Silicone Filled							○	○				○	○	○	○	○		
316SS, Wetted Parts													○	○	○	○	○	○
316SS, All													○	○	○	○		
Tagging	○	○	○	○	○	○	○	○	○	○	○	○	○	○	○	○	○	○
Custom Dial Imprinting	○	○	○	○	○	○	○	○	○	○	○	○	○	○	○	○	○	○
Stem Lengths	Intermediate lengths available upon request. 18" Maximum										Intermediate lengths available upon request. 120" Maximum							

✓ Standard configuration.

† Polycarbonate lens standard up to 300°F (150°C), Glass lens standard over 300°F (150°C). Do Not subject Polycarbonate lens to temperatures over 270°F (130°C).

○ Available options.

3", 4" and 5" Adjustable Angle Industrial Thermometers

- Maximum utility for installation
- Head can be rotated 360°
- Stem positioning over 180°

Heavy Duty design, with versatile case and stem that can be adjusted to almost any angle for easy viewing. Preferred by the process, offshore, power, pharmaceutical and chemical industries.

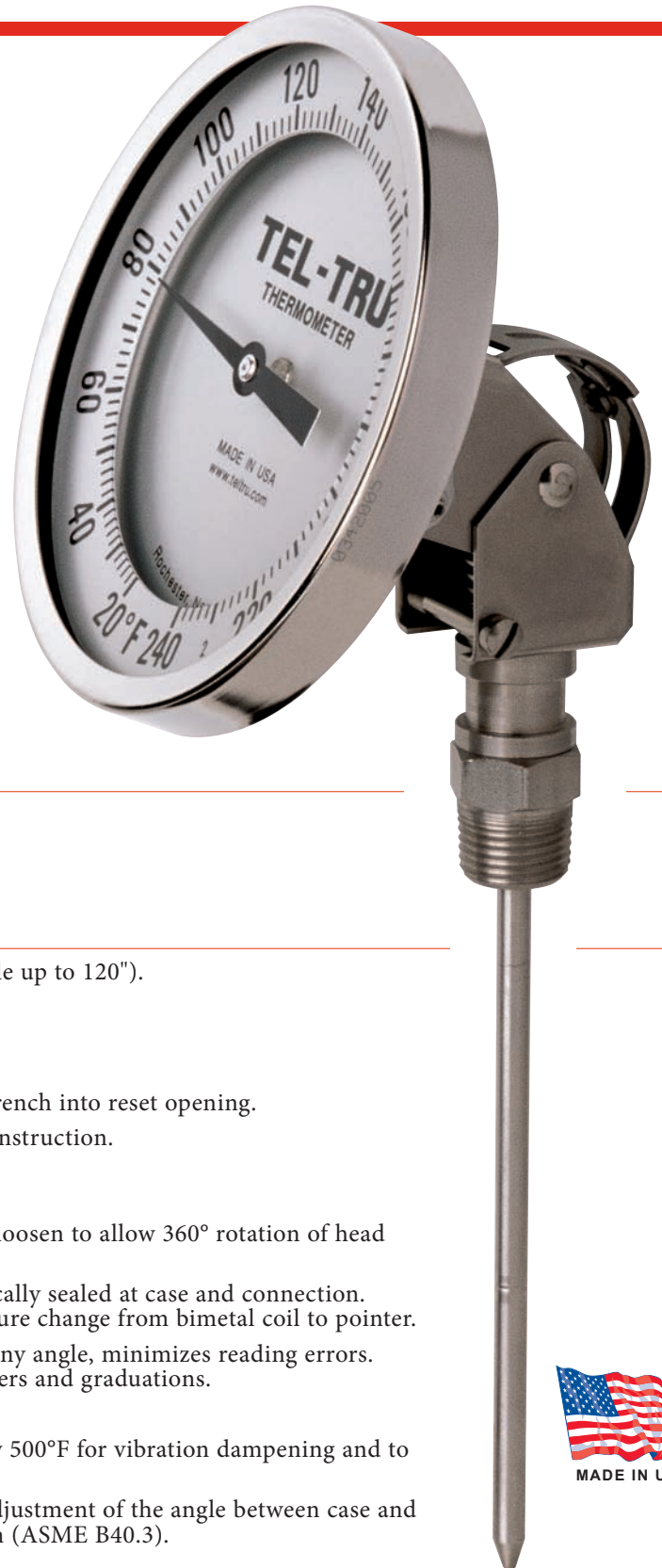
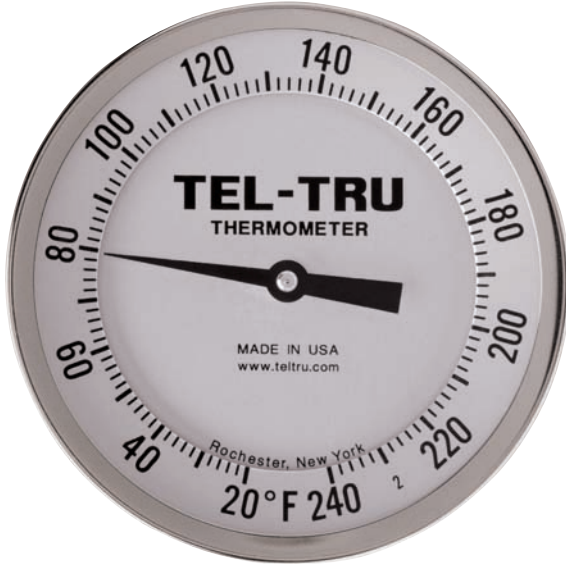

► MODEL CODES:

AA-375R	3" diameter head with calibration feature
AA-475R	4" diameter head with calibration feature
AA-575R	5" diameter head with calibration feature

► SPECIFICATIONS:

Stem Lengths:	2½", 4", 6", 9", 12", 15", 18" and 24" (available up to 120").
Stem Diameter:	.250" standard up to 42" stem. .375" standard over 42" stem.
Connection:	½" NPT.
External Reset:	Easy to calibrate by inserting 1/16" Allen wrench into reset opening.
Construction:	304 stainless steel external parts. Welded construction. Corrosion resistant to most chemicals.
Hermetic seal:	Per ASME B40.3 dustproof and leakproof.
Harness:	All stainless steel brackets with screws that loosen to allow 360° rotation of head and 180° adjustment of stem position.
Bellows:	Heavy-duty flexible stainless steel. Hermetically sealed at case and connection. Protects mechanism that transfers temperature change from bimetal coil to pointer.
Dial:	True Anti-Parallax dial, easy-to-read from any angle, minimizes reading errors. Anodized aluminum with large black numbers and graduations.
Lens:	Glass.
Bimetal Coil:	Helix coil is silicone coated on ranges below 500°F for vibration dampening and to maximize heat transfer and response time.
Accuracy:	±1% full span per ASME B40.3 Grade A. Adjustment of the angle between case and stem may affect accuracy up to 0.5% of span (ASME B40.3).
Over Temperature Limits:	Up to 250°F 100%; 250°F to 550°F, 50%; 550°F to 1000°F, continuous use up to 800°F, intermittent use over 800°F.



MADE IN USA



Tel-Tru® Manufacturing Company

408 St. Paul St., Rochester, New York 14605 USA

Phone: 585.232.1440 • 800.232.5335 • Fax: 585.232.3857 • E-mail: info@teltru.com • Web: www.teltru.com

➤ **STANDARD RANGES:**

Fahrenheit	°/Div.	Celsius	°/Div.	Dual	
				Fahrenheit	Celsius
-100/100°	2°	-75/175°	5°	-100/100	-75/40
-50/120°	2°	-70/70°	1°	-40/160	-40/70
-40/160°	2°	-50/100°	1°	-0/140	-18/60
0/140°	1°	-50/25°	1°	0/180	-18/82
0/180°	2°	-50/50°	1°	0/220	-10/100
0/200°	2°	-40/70°	1°	0/250	-20/120
0/220°	2°	-20/120°	1°	20/240	-10/110
0/250°	2°	-10/110°	1°	25/125	-5/50
0/300°	5°	0/50°	1/2°	50/300	10/150
0/500°	10°	0/60°	1°	50/400	0/200
20/240°	2°	0/80°	1/2°	50/500	10/260
25/125°	1°	0/100°	1°	150/750	50/400
50/250°	2°	0/150°	1°	* 200/1000	* 100/550
50/300°	2°	0/200°	2°		
50/400°	5°	0/250°	2°		
50/500°	5°	0/300°	5°		
50/550°	5°	0/400°	5°		
100/800°	10°	0/450°	5°		
150/750°	10°	100/400°	5°		
* 200/1000°	10°	* 100/550°	5°		

(Additional Ranges Available – Consult factory)

* Thermometers with temperature ranges 200/1000°F and 100/550°C are NOT RECOMMENDED FOR CONTINUOUS USE ABOVE 800°F/425°C (FOR INTERMITTENT USE ONLY).

➤ **OPTIONS:**

- Union connection or other connection types and sizes.
- Silicone filled.
- Other lenses are acrylic, polycarbonate, shatterproof glass or tempered glass.
- Other stem diameters .236" (6mm), .315" (8mm), .375" (9.52mm).
- 316SS wetted parts.
- Other configuration combinations available upon request.

Estimated Shipping Weights		
MODEL	DRY	SILICONE FILLED
AA-375R	. 1lb. 1lb. 3oz.
AA-475R	. 1lb. 8oz. 1lb. 14oz.
AA-575R	. 1lb. 12oz. 2lb. 6oz.

➤ **AA-375R, AA-475R AND AA-575R**

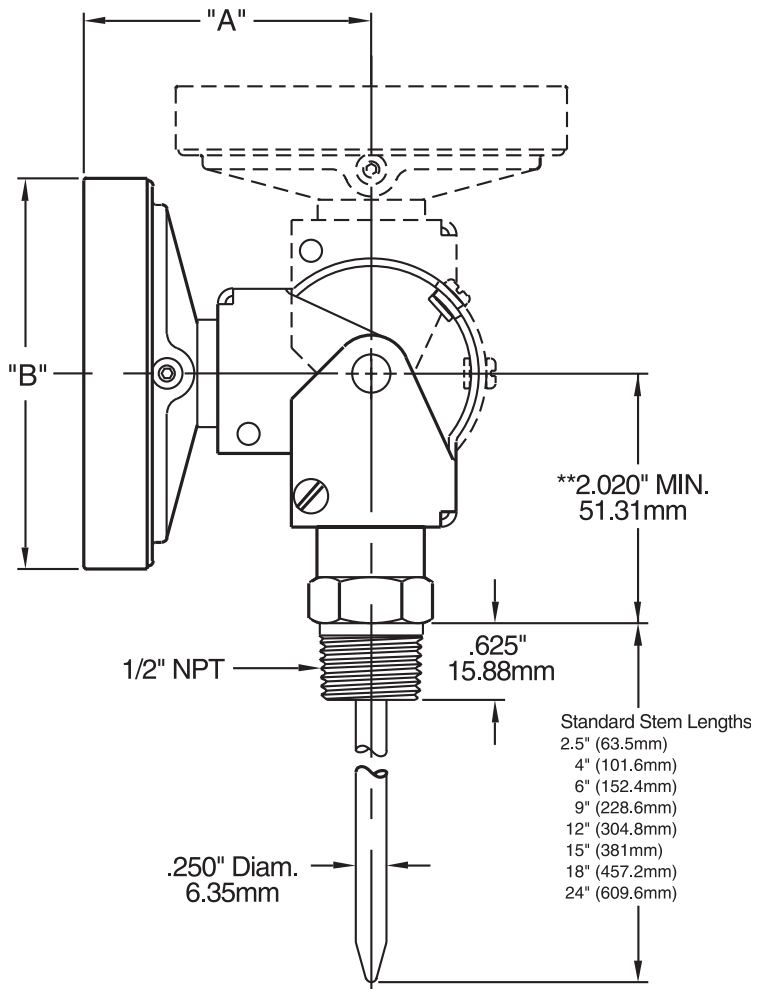

MODEL	"A"	"B"
AA-375R	2.430" (61.72mm)	3.187" (80.95mm)
AA-475R	2.430" (61.72mm)	4.115" (104.50mm)
AA-575R, UT575	2.660" (67.56mm)	5.040" (128.02mm)

** Contact factory if specific dimension is required for OEM applications.

➤ **FOR HOW TO ORDER, SEE PAGE 6**

➤ **IMPORTANT NOTES:**

- 1) Thermowells are recommended for pressure, corrosive fluid or high velocity applications.
- 2) ASME B40.3— Bimetal thermometers manufactured by Tel-Tru and offered in this brochure are designed to meet or exceed this Standard issued by the American Society of Mechanical Engineers.

3", 4" and 5" Back Connected Industrial Thermometers

A rugged 90° back angle, rear threaded connection design. Commonly used in industrial, pulp and paper, food and beverage processing, HVAC, and OEM applications.



► MODEL CODES:

GT-300	3" diameter head
GT-300R	3" diameter head with calibration feature
MX-325R	3" diameter head with calibration feature and min <i>or</i> max temperature indicator
MM-325R	3" diameter head with calibration feature and min <i>and</i> max temperature indicator
GT-400	4" diameter head
GT-400R	4" diameter head with calibration feature
GT-500	5" diameter head
GT-500R	5" diameter head with calibration feature
MX-525R	5" diameter head with calibration feature and min <i>or</i> max temperature indicator
MM-525R	5" diameter head with calibration feature and min <i>and</i> max temperature indicator

► SPECIFICATIONS:

Stem Lengths:	2½", 4", 6", 9", 12", 15", 18" and 24" (available up to 120").
Stem Diameter:	.250" standard up to 42" stem. .375" standard over 42" stem.
Connection:	½" NPT.
External Reset:	Models with calibration feature are easy to calibrate by inserting ⅛" Allen wrench into reset opening.
Construction:	304 stainless steel external parts. Welded construction. Corrosion resistant to most chemicals.
Hermetic seal:	Per ASME B40.3 dustproof and leakproof.
Dial:	True Anti-Parallax dial, easy-to-read from any angle, minimizes reading errors. Anodized aluminum with large black numbers and graduations.
Lens:	Glass.
Bimetal Coil:	Helix coil is silicone coated on ranges below 500°F for vibration dampening and to maximize heat transfer and response time.
Accuracy:	±1% full span per ASME B40.3 Grade A. When using maximum or minimum temperature indicator, accurate to within 1½% full span.
Over Temperature Limits:	Up to 250°F 100%; 250°F to 550°F, 50%; 550°F to 1000°F, continuous use up to 800°F, intermittent use over 800°F.





Tel-Tru® Manufacturing Company

408 St. Paul St., Rochester, New York 14605 USA

Phone: 585.232.1440 • 800.232.5335 • Fax: 585.232.3857 • E-mail: info@teltru.com • Web: www.teltru.com

➤ **STANDARD RANGES:**

Fahrenheit	°/Div.	Celsius	°/Div.	Dual	
				Fahrenheit	Celsius
-100/100°	2°	-75/175°	5°	-100/100	-75/40
-50/120°	2°	-70/70°	1°	-40/160	-40/70
-40/160°	2°	-50/100°	1°	-0/140	-18/60
0/140°	1°	-50/25°	1°	0/180	-18/82
0/180°	2°	-50/50°	1°	0/220	-10/100
0/200°	2°	-40/70°	1°	0/250	-20/120
0/220°	2°	-20/120°	1°	20/240	-10/110
0/250°	2°	-10/110°	1°	25/125	-5/50
0/300°	5°	0/50°	1/2°	50/300	10/150
0/500°	10°	0/60°	1°	50/400	0/200
20/240°	2°	0/80°	1/2°	50/500	10/260
25/125°	1°	0/100°	1°	150/750	50/400
50/250°	2°	0/150°	1°	* 200/1000	* 100/550
50/300°	2°	0/200°	2°		
50/400°	5°	0/250°	2°		
50/500°	5°	0/300°	5°		
50/550°	5°	0/400°	5°		
100/800°	10°	0/450°	5°		
150/750°	10°	100/400°	5°		
* 200/1000°	10°	* 100/550°	5°		

(Additional Ranges Available – Consult factory)

* Thermometers with temperature ranges 200/1000°F and 100/550°C are NOT RECOMMENDED FOR CONTINUOUS USE ABOVE 800°F/425°C (FOR INTERMITTENT USE ONLY).

➤ **OPTIONS:**

- Union connection or other connection types and sizes.
- Silicone filled.
- Other lenses are acrylic, polycarbonate, shatterproof glass or tempered glass (except MX and MM models).
- Other stem diameters .236" (6mm), .315" (8mm), .375" (9.5mm).
- 316SS wetted parts.
- Other configuration combinations available upon request.
- Some ranges NSF® certified.

MODEL	Estimated Shipping Weights	
	DRY	SILICONE FILLED
GT-300 and GT-300R	11 oz.	14 oz.
GT-400 and GT-400R	1 lb.	1 lb. 6 oz.
GT-500 and GT-500R	1 lb. 4 oz.	1 lb. 14 oz.
MX-325R and MM-325R	11 oz.	N/A
MX-525R and MM-525R	1 lb. 4 oz.	N/A

➤ **GT-300, GT-300R, GT-400, GT-400R, GT-500, GT-500R, MX-325R, MM-325R, MX-525R, MM-525R**

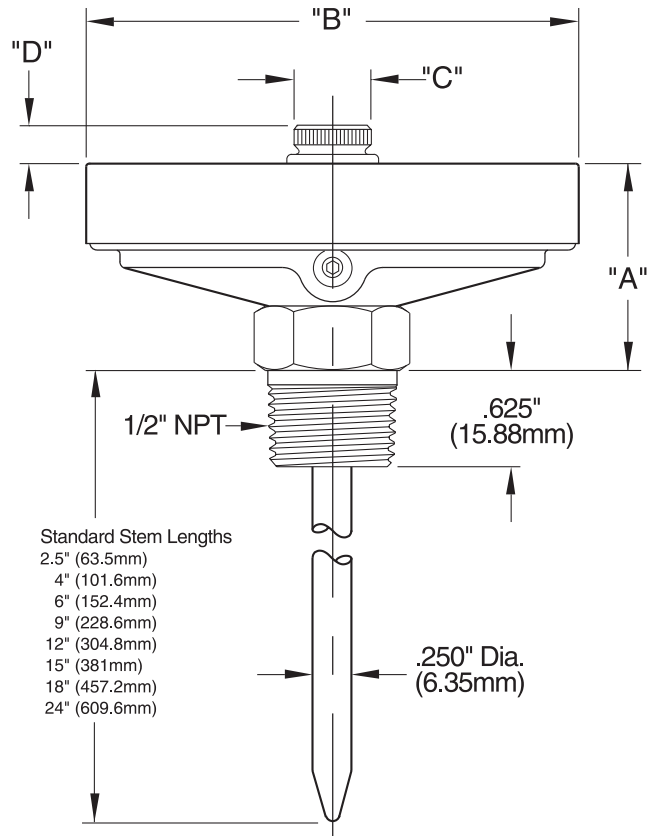

MODEL	"A"	"B"	"C"	"D"
GT-300, GT-300R	1.375" (34.93mm)	3.187" (80.95mm)	N/A	N/A
GT-400, GT-400R	1.375" (34.93mm)	4.115" (104.50mm)	N/A	N/A
GT-500, GT-500R, UT500	1.718" (43.63mm)	5.040" (128.02mm)	N/A	N/A
MX-325R	1.375" (34.93mm)	3.187" (80.95mm)	.500" (12.70mm)	.275" (6.99mm)
MM-325R	1.375" (34.93mm)	3.187" (80.95mm)	.625" (15.88mm)	.438" (11.12mm)
MX-525R	1.718" (43.63mm)	5.040" (128.02mm)	.500" (12.70mm)	.275" (6.99mm)
MM-525R	1.718" (43.63mm)	5.040" (128.02mm)	.625" (15.88mm)	.438" (11.12mm)

➤ **FOR HOW TO ORDER, SEE PAGE 6**

➤ **IMPORTANT NOTES:**

- 1) Thermowells are recommended for pressure, corrosive fluid or high velocity applications.
- 2) ASME B40.3— Bimetal thermometers manufactured by Tel-Tru and offered in this brochure are designed to meet or exceed this Standard issued by the American Society of Mechanical Engineers.

3", 4" and 5" Bottom Connected Industrial Thermometers

A sturdy straight form design commonly used for industrial applications and OEM equipment.

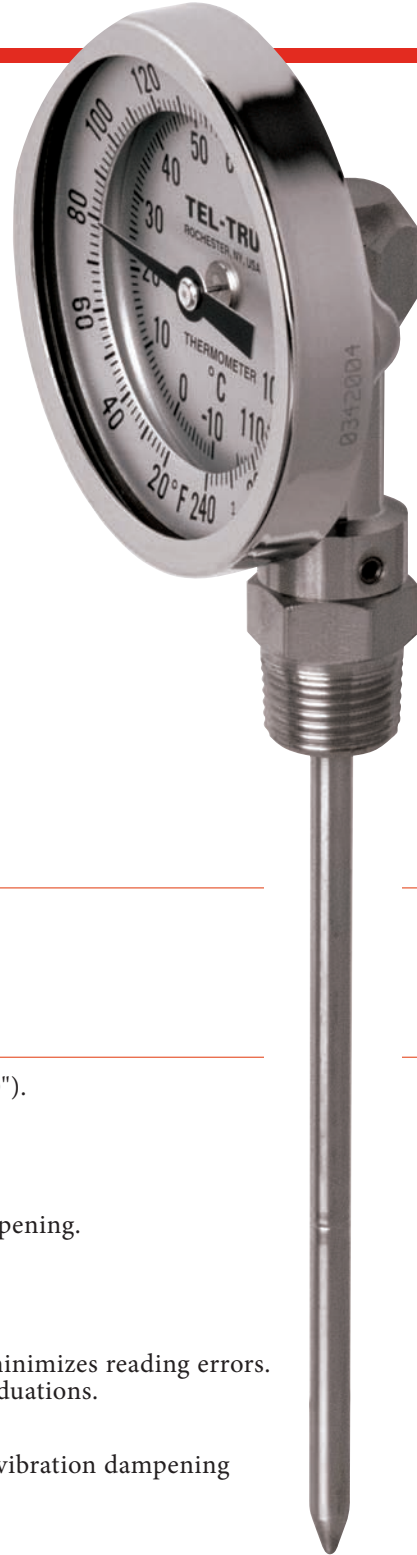

► MODEL CODES:

BC-350R	3" diameter head with calibration feature
BC-450R	4" diameter head with calibration feature
BC-550R	5" diameter head with calibration feature

► SPECIFICATIONS:

Stem Lengths:	2½", 4", 6", 9", 12", 15", 18" and 24" (available up to 120").
Stem Diameter:	.250" standard up to 42" stem. .375" standard over 42" stem.
Connection:	½" NPT.
External Reset:	Easy to calibrate by inserting Allen wrench into reset opening.
Construction:	304 stainless steel external parts. Welded construction. Corrosion resistant to most chemicals.
Hermetic seal:	Per ASME B40.3 dustproof and leakproof.
Dial:	True Anti-Parallax dial, easy-to-read from any angle, minimizes reading errors. Anodized aluminum with large black numbers and graduations.
Lens:	Glass.
Bimetal Coil:	Helix coil is silicone coated on ranges below 500°F for vibration dampening and to maximize heat transfer and response time.
Accuracy:	±1% full span per ASME B40.3 Grade A.
Over Temperature Limits:	Up to 250°F 100%; 250°F to 550°F, 50%; 550°F to 1000°F, continuous use up to 800°F, intermittent use over 800°F.





Tel-Tru® Manufacturing Company

408 St. Paul St., Rochester, New York 14605 USA

Phone: 585.232.1440 • 800.232.5335 • Fax: 585.232.3857 • E-mail: info@teltru.com • Web: www.teltru.com

➤ **STANDARD RANGES:**

Fahrenheit	°/Div.	Celsius	°/Div.	Dual	
				Fahrenheit	Celsius
-100/100	2°	-75/175	5°	-100/100	-75/40
-50/120	2°	-70/70	1°	-40/160	-40/70
-40/160	2°	-50/100	1°	0/140	-18/60
0/140	1°	-50/25	1°	0/180	-18/82
0/180	2°	-50/50	1°	0/220	-10/100
0/200	2°	-40/70	1°	0/250	-20/120
0/220	2°	-20/120	1°	20/240	-10/110
0/250	2°	-10/110	1°	25/125	-5/50
0/300	5°	0/50	1/2°	50/300	10/150
0/500	10°	0/60	1°	50/400	0/200
20/240	2°	0/80	1/2°	50/500	10/260
25/125	1°	0/100	1°	150/750	50/400
50/250	2°	0/150	1°	* 200/1000	*100/550
50/300	2°	0/200	2°		
50/400	5°	0/250	2°		
50/500	5°	0/300	5°		
50/550	5°	0/400	5°		
100/800	10°	0/450	5°		
150/750	10°	100/400	5°		
* 200/1000	10°	* 100/550	5°		

(Additional Ranges Available – Consult factory)

* Thermometers with temperature ranges 200/1000°F and 100/550°C are NOT RECOMMENDED FOR CONTINUOUS USE ABOVE 800°F/425°C (FOR INTERMITTENT USE ONLY).

➤ **OPTIONS:**

- Stem Position available in TOP (12:00), RIGHT (3:00), or LEFT (9:00) side connections (specify position of stem when ordering).
- Union connection or other connection types and sizes.
- Silicone filled.
- Other lenses are acrylic, polycarbonate, shatterproof glass or tempered glass.
- Other stem diameters .236" (6mm), .315" (8mm), .375" (9.5mm).
- 316SS wetted parts.
- Other configuration combinations available upon request.

Estimated Shipping Weights		
MODEL	DRY	SILICONE FILLED
BC-350R	. 14 oz.	1 lb. 1 oz.
BC-450R	. 1 lb. 3 oz. . . .	1 lb. 9 oz.
BC-550R	. 1 lb. 10 oz. . .	2 lb. 4 oz.

➤ **FOR HOW TO ORDER, SEE PAGE 6**

➤ **IMPORTANT NOTES:**

- 1) Thermowells are recommended for pressure, corrosive fluid or high velocity applications.
- 2) ASME B40.3— Bimetal thermometers manufactured by Tel-Tru and offered in this brochure are designed to meet or exceed this Standard issued by the American Society of Mechanical Engineers.

➤ **BC-350R, BC-450R AND BC-550R**

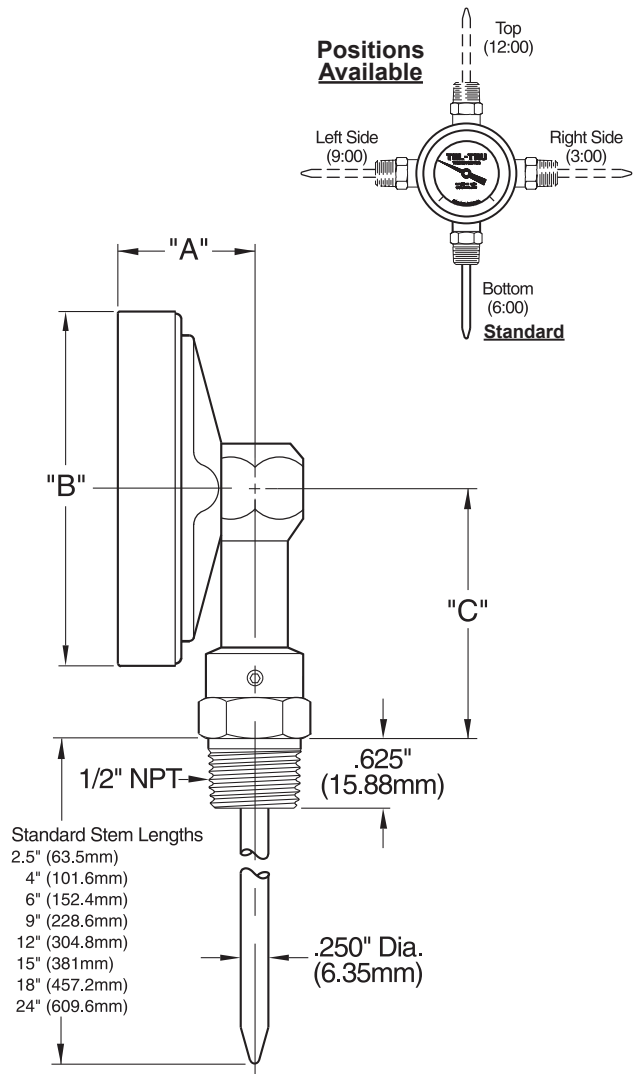

MODEL	"A"	"B"	"C"
BC-350R	1.187" (30.15mm)	3.187" (80.95mm)	2.300" (58.42mm)
BC-450R	1.187" (30.15mm)	4.115" (104.50mm)	3.000" (76.20mm)
BC-550R	1.625" (41.28mm)	5.040" (128.02mm)	3.000" (76.20mm)

1³/₄" and 2" Back Connected Industrial Thermometers

A smaller size, heavy duty, rear connected unit commonly used in OEM equipment and light industrial applications.

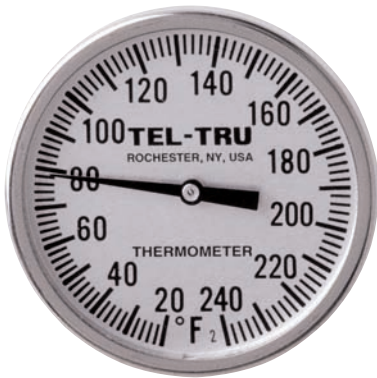

GT-200
(With 1³/₄" dial)

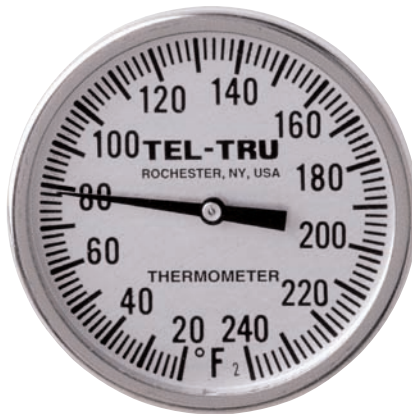

LN-250
(With 2" dial)



► MODEL CODES:

GT-200	1 ³ / ₄ " diameter head
GT-225	2" diameter head
LN-250	2" diameter head
LN-250R	2" diameter head with calibration feature

► SPECIFICATIONS:

Stem Lengths:	GT Models 2 ¹ / ₂ ", 4", 6", 8", 12", and 18". LN Models 2 ¹ / ₂ ", 4", 6", 9", 12", 15", 18" and 24" (available up to 120").
Stem Diameter:	GT model .150" standard up to 18" stem. LN model .250" standard up to 42" stem. LN model .375" is standard over 42" stem.
Connection:	GT models 1/8", 1/4", or 3/8" NPT is standard. LN models 1/4" NPT is standard.
External Reset:	LN-250R is easy to calibrate by loosening the socket head screw (above hex connecting nut) with 5/64" Allen wrench.
Construction:	304 stainless steel external parts. Welded construction. Corrosion resistant to most chemicals.
Hermetic seal:	Per ASME B40.3 dustproof and leakproof.
Dial:	Anodized aluminum with large black numbers and graduations.
Lens:	Glass.
Bimetal Coil:	Helix coil is silicone coated on ranges below 500°F for vibration dampening and to maximize heat transfer and response time.
Accuracy:	±1% full span per ASME B40.3 Grade A.
Over Temperature Limits:	Up to 250°F 100%; 250°F to 550°F, 50%; 550°F to 1000°F, continuous use up to 800°F, intermittent use over 800°F.





Tel-Tru® Manufacturing Company

408 St. Paul St., Rochester, New York 14605 USA

Phone: 585.232.1440 • 800.232.5335 • Fax: 585.232.3857 • E-mail: info@teltru.com • Web: www.teltru.com

➤ **STANDARD RANGES:**

Fahrenheit	°/Div.	Celsius	°/Div.	Dual	
				Fahrenheit	Celsius
-100/100	2°	-75/175	5°	-100/100	-75/40
-50/120	2°	-50/100	1°	-40/160	-40/70
-40/160	2°	-50/25	1°	0/140	-18/60
0/140	2°	-50/50	1°	0/180	-18/82
0/180	2°	-40/70	1°	0/220	-10/100
0/200	2°	-20/120	1°	0/250	-20/120
0/220	2°	-10/110	1°	20/240	-10/110
0/250	2°	0/50	1/2°	25/125	0/50
20/240	2°	0/100	1°	50/300	10/150
25/125	1°	0/150	1°	50/400	0/200
50/250	2°	0/200	2°	50/500	0/250
50/300	2°	0/250	2°	150/750	50/400
50/400	5°	0/300	5°	* 200/1000	* 100/550
50/500	5°	0/400	5°		
50/550	5°	100/400	5°		
150/750	10°	* 100/550	5°		
* 200/1000	10°				

(Additional Ranges Available – Consult factory)

* Thermometers with temperature ranges 200/1000°F and 100/550°C are NOT RECOMMENDED FOR CONTINUOUS USE ABOVE 800°F/425°C (FOR INTERMITTENT USE ONLY).

➤ **GT-200, GT-225, AND LN-250**

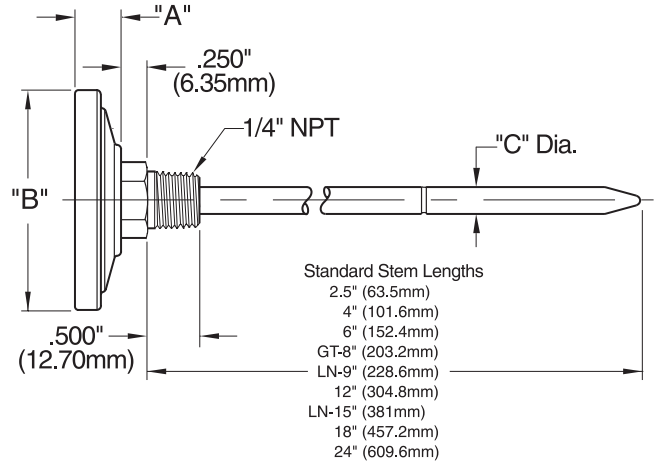

MODEL	"A"	"B"	"C"
GT-200	.350" (8.89mm)	1.750" (44.45mm)	.150" (3.81mm)
GT-225	.438" (11.13mm)	2.089" (53.06mm)	.150" (3.81mm)
LN-250	.438" (11.13mm)	2.089" (53.06mm)	.250" (6.35mm)

➤ **OPTIONS:**

- Other threaded or plain connections.
- Silicone filled.
- Other lenses are acrylic, polycarbonate or tempered glass.
- Other stem diameters GT-200/GT225 .140" (3.6mm) models. LN-250 .236" (6mm) and .375" (9.5mm).
- Other configuration combinations available upon request.

Estimated Shipping Weights		
MODEL	DRY	SILICONE FILLED
GT-200	3 oz.	N/A
GT-225	3 oz.	.5 oz.
LN-250 and LN-250R	5 oz.	.9 oz.

➤ **LN-250R**

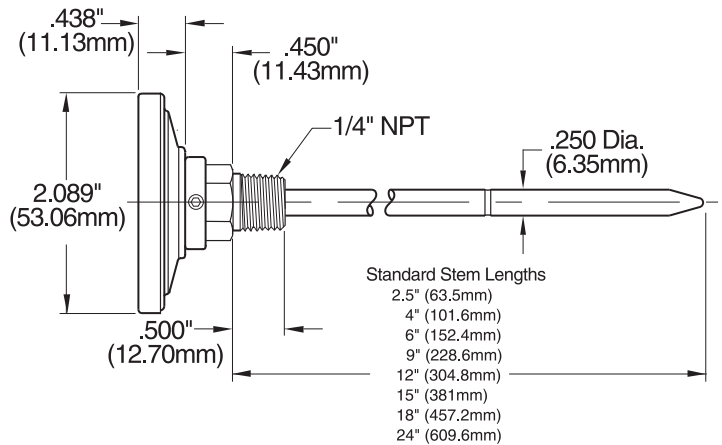

➤ **FOR HOW TO ORDER, SEE PAGE 6**

➤ **IMPORTANT NOTES:**

- 1) Thermowells are recommended for pressure, corrosive fluid or high velocity applications.
- 2) ASME B40.3— Bimetal thermometers manufactured by Tel-Tru and offered in this brochure are designed to meet or exceed this Standard issued by the American Society of Mechanical Engineers.

1³/₄", 2" and 3" Laboratory Testing and General Purpose Thermometers

These models are used for general-purpose testing applications such as laboratory, food, concrete, asphalt, soil and photography and OEM equipment.

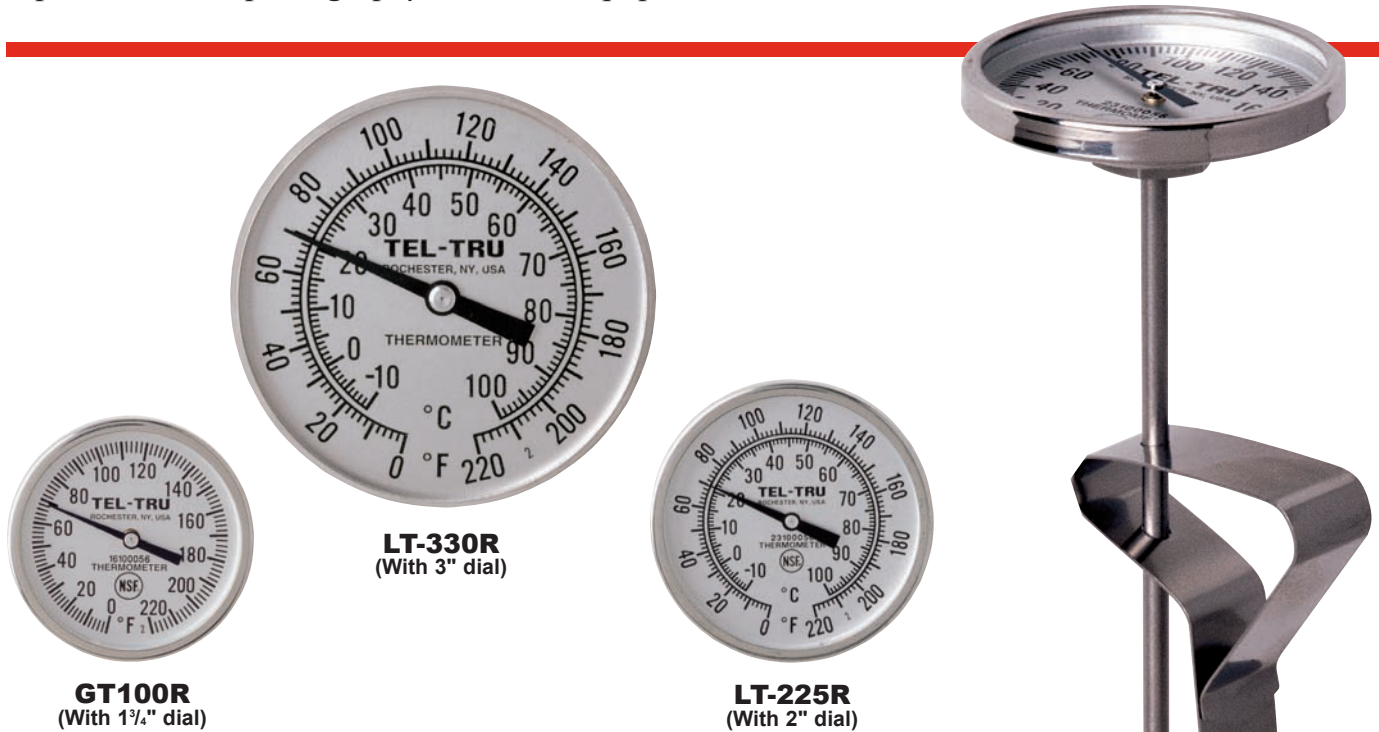

► MODEL CODES:

GT-100 and MT-39	1 ³ / ₄ " diameter head
GT-100R and MT-39R	1 ³ / ₄ " diameter head with calibration feature
LT-225	2" diameter head
LT-225R and BT-275R	2" diameter head with calibration feature
LT-330R	3" diameter head with calibration feature

► SPECIFICATIONS:

Stem Lengths:	5", 8", 12" and 18".
Stem Diameter:	.150" standard up to 18" stem.
Connection:	GT-100, MT-39 and LT-225 plain bushing is standard. GT-100R, MT-39R, LT225R, BT-275R and LT-330R recalibrating nut is standard.
External Reset:	GT-100R, MT-39R, LT-225R, BT-275R and LT-330R friction nut design for easy calibration.
Construction:	304 stainless steel external parts. Welded construction. Corrosion resistant to most chemicals.
Hermetic seal:	Per ASME B40.3 dustproof and leakproof.
Dial:	Anodized aluminum with large black numbers and graduations.
Lens:	GT, MT, and LT models glass is standard. LT-330R polycarbonate lens is standard.
Bimetal Coil:	Helix coil is silicone coated on ranges below 500°F for vibration dampening and to maximize heat transfer and response time.
Accuracy:	±1% full span per ASME B40.3 Grade A.
Over Temperature Limits:	Up to 250°F 100%; 250°F to 550°F, 50%; 550°F to 1000°F, continuous use up to 800°F, intermittent use over 800°F.
Adjustable Pan Clip:	Standard on 5" and 8" GT-100R, LT-225R and LT-330R (for tank and tray mounting).





Tel-Tru® Manufacturing Company

408 St. Paul St., Rochester, New York 14605 USA

Phone: 585.232.1440 • 800.232.5335 • Fax: 585.232.3857 • E-mail: info@teltru.com • Web: www.teltru.com

➤ **STANDARD RANGES 1 3/4" AND 2" MODELS:**

Fahrenheit		%/Div.	Celsius		Dual	
Fahrenheit		%/Div.	Celsius		Fahrenheit	Celsius
-100/100	2°	-75/175	5°	-100/100	-75/40	
-50/120	2°	-50/100	1°	-40/160	-40/70	
-40/160	2°	-50/25	1°	0/140	-18/60	
0/140	2°	-50/50	1°	0/180	-18/82	
0/180	2°	-40/70	1°	0/220	-10/100	
0/200	2°	-20/120	1°	0/250	-20/120	
0/220	2°	-10/110	1°	20/240	-10/110	
0/250	2°	0/50	1/2°	25/125	0/50	
20/240	2°	0/100	1°	50/300	10/150	
25/125	1°	0/150	1°	50/400	0/200	
50/250	2°	0/200	2°	50/500	0/250	
50/300	2°	0/250	2°	150/750	50/400	
50/400	5°	0/300	5°	* 200/1000	* 100/550	
50/500	5°	0/400	5°			
50/550	5°	100/400	5°			
150/750	10°	* 100/550	5°			
* 200/1000	10°					

➤ **DUAL TEMPERATURE RANGES MODEL LT-330R:**

Fahrenheit		%/Div.	Celsius		Est. Shipping Weights DRY	
Fahrenheit		%/Div.	Celsius		MODEL	DRY
-100/100	2°	-75/40	2°	MT-39 and MT-39R... 4 oz.		
-40/160	2°	-40/70	1°	GT-100 and GT-100R... 3 oz.		
0/220	2°	-10/100	1°	LT-225 and LT-225R... 4 oz.		
25/125	1°	0/50	1/2°	LT-330R and BT-275R . 8 oz.		
50/300	2°	10/150	2°			
50/500	5°	0/250	2°			
150/750	10°	50/400	5°			
* 200/1000	10°	* 100/550	5°			

Notes for above tables:

(Additional Ranges Available- Consult factory)

* Thermometers with temperature ranges 200/1000°F and 100/550°C are NOT RECOMMENDED FOR CONTINUOUS USE ABOVE 800°F/425°C (FOR INTERMITTENT USE ONLY).

➤ **OPTIONS:**

- Threaded connections on non-recal models.
- Other lenses are acrylic, polycarbonate or tempered glass.
- Other stem diameters .140" (3.6mm) and .187" (4.7mm).
- Pocket sheath for 5" or 8" stem.
- Silicone fill on LT225 and LT225R.
- Other configuration combinations available upon request.

➤ **FOR HOW TO ORDER, SEE PAGE 6**

➤ **IMPORTANT NOTES:**

- 1) IMMERSION- For most accurate reading with Tel-Tru thermometers immerse past groove on lower portion of stem.
- 2) MT and BT models are designed with Tel-Tru unique pressure relief ring feature designed to prevent pressure build up in thermometer head while cooking in hot oven.
- 3) Some models and ranges are NSF® certified (National Sanitation Foundation).

➤ **GT-100R, MT-39R, BT-275R AND LT-225R**

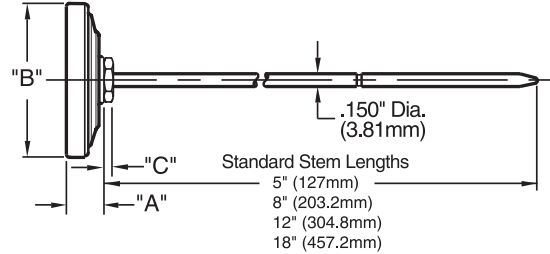

MODEL	"A"	"B"	"C"
GT-100R, MT-39R	.412" (10.47mm)	1.750" (44.45mm)	.102" (2.59mm)
LT-225R, BT-275R	.438" (11.13mm)	2.089" (53.06mm)	.120" (3.05mm)

➤ **GT-100, MT-39, and LT-225**

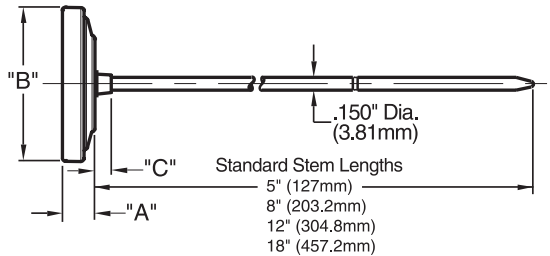

MODEL	"A"	"B"	"C"
GT-100, MT-39	.350" (8.89mm)	1.750" (44.45mm)	.187" (4.75mm)
LT-225	.438" (11.13mm)	2.089" (53.06mm)	.250" (6.35mm)

➤ **LT-330R**

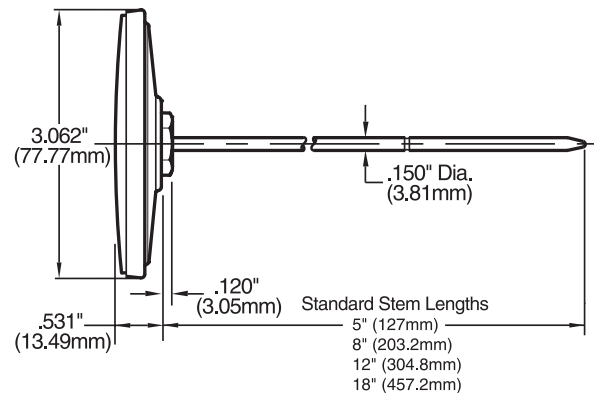

1" and 1³/₈" Testing and Spot Checking Thermometers

A pocket sized thermometer used by inspectors, service and maintenance personnel, and technicians for general checking in food service, refrigeration, air conditioning, hot asphalt and food processing applications. Often modified for OEMs to use in limited space situations.



AD-44R
(Standard,
with 1³/₈" dial)



PT-50R
(Standard dial,
with 1" dial)



PT-50R
(Shown with
pocket sheath)

► MODEL CODES:

PT-50	1" diameter head
PT-50R	1" diameter head with calibration feature
AD-10R	1" diameter head with calibration feature
AD-44R	1 ³ / ₈ " diameter head with calibration feature

► SPECIFICATIONS:

Stem Length:	5" (127mm)
Stem Diameter:	.150"
Connection:	PT-50 model plain bushing is standard. PT-50R, AD10R and AD44R recal nut is standard.
External Reset:	PT50R, AD10R, AD44R and MT39R friction nut design for easy calibration.
Construction:	304 stainless steel external parts. Welded construction. Corrosion resistant to most chemicals.
Hermetic seal:	Per ASME B40.3 dustproof and leakproof.
Dial:	Anodized aluminum with large black numbers and graduations. Glow dial available on PT50R and AD44R.
Lens:	AD10R and AD44R models polycarbonate lens is standard. PT50 and PT50R models polycarbonate lens is standard up to 300°F (150°C) and glass lens over 300°F (150°C).
Bimetal Coil:	Helix coil is silicone coated on ranges below 500°F for vibration dampening and to maximize heat transfer and response time.
Accuracy:	±1% full span per ASME B40.3 Grade A.
Over Temperature Limits:	Up to 250°F 100%; 250°F to 550°F, 50%; 550°F to 1000°F, continuous use up to 800°F, intermittent use over 800°F.
Pocket sheath:	Standard on 5" PT50R, AD10R and AD44R.



MADE IN USA



Tel-Tru® Manufacturing Company

408 St. Paul St., Rochester, New York 14605 USA

Phone: 585.232.1440 • 800.232.5335 • Fax: 585.232.3857 • E-mail: info@teltru.com • Web: www.teltru.com

➤ **STANDARD RANGES:**

Fahrenheit	°/Division	Celsius	°/Division
* -40/160	2°	-40/70	1°
25/125	1°	-10/110	1°
* 0/220	2°	0/50	1/2°
* 50/500	5°	0/250	5°
150/750	10°		

(Additional Ranges Available— Consult factory)

* NSF® approved for food service applications on models PT-50R, AD-10R and AD-44R

➤ **OPTIONS:**

- .140" stem diameter.
- Threaded connections for OEM applications.
- Other configuration combinations available upon request.
- Glow dial available on PT50R and AD44R.

Estimated Shipping Weights	
MODEL	DRY
PT-50 and PT-50R	1 oz.
AD-10R	1 oz.
AD-44R	2 oz.

➤ **PT-50**

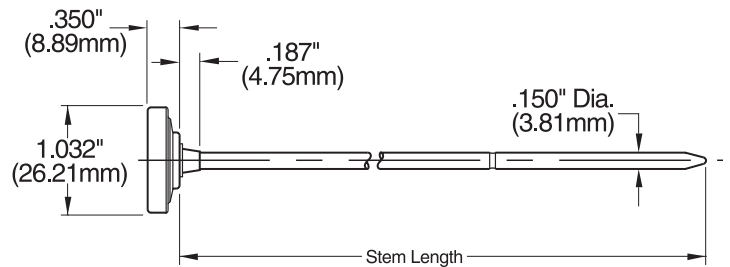

➤ **PT-50R**

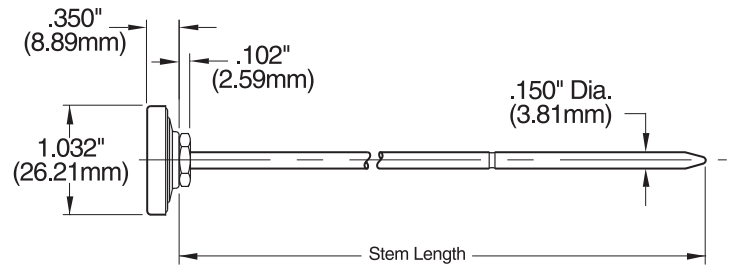

➤ **AD-10R AND AD-44R**

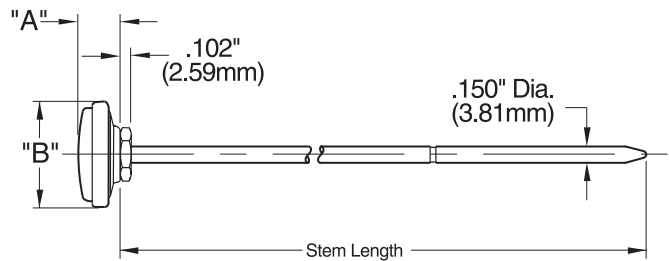

MODEL	"A"	"B"
AD-10R	.400" (10.16mm)	1.004" (25.50mm)
AD-44R	.456" (11.58mm)	1.358" (34.50mm)

➤ **FOR HOW TO ORDER, SEE PAGE 6**

➤ **IMPORTANT NOTES:**

- 1) IMMERSION – For most accurate reading with Tel-Tru thermometers immerse past groove on lower portion of stem.
- 2) CAUTION – Do not subject polycarbonate lens to temperatures above 270°F (130°C).

Options and Accessories

➤ CONNECTIONS AND FITTINGS

Many thread types and sizes are manufactured on Tel-Tru CNC machines. 304SS and 316SS.



➤ LENSES

Shatterproof and tempered glass, acrylic and polycarbonate plastic.



➤ DIALS

Precision pad printing of custom logos, colored zones and special information on all dial sizes.



➤ TAGGING

Paper, aluminum, 304SS or 316SS tags for engineering project requirements.

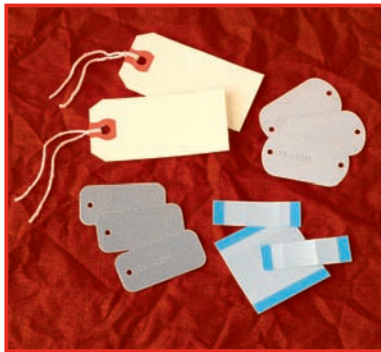

➤ MOUNTING FLANGES

Various size mounting flanges for OEM and duct applications.



➤ THERMOWELL ADAPTER KIT:

The AS-86 adapter kit was designed as a simple means of converting existing Industrial Glass Thermometer Wells for use with Bimetal Thermometers.

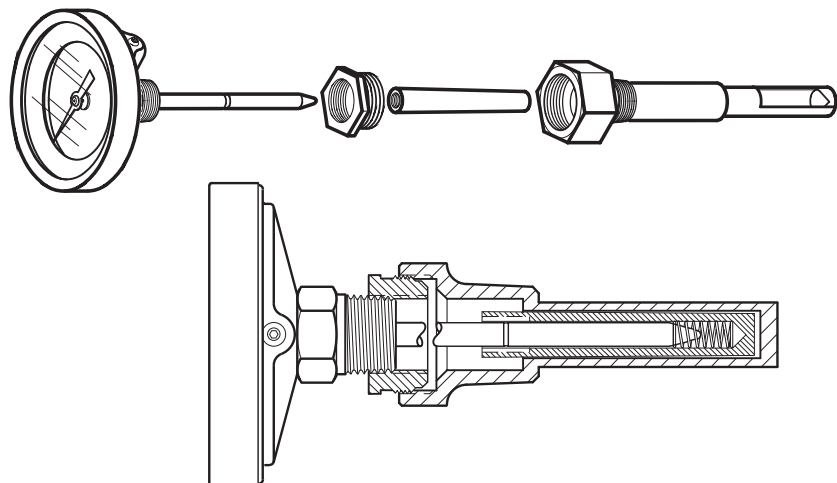
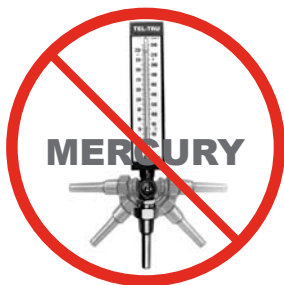

Thermowells

Recommended for pressure, corrosive fluid and high velocity applications.

➤ SEE TEL-TRU THERMOWELL CATALOG

For complete dimensions, sizes, available materials, optional features and configurations. For technical data on pressure and temperature ratings and maximum fluid velocity see <http://www.teltru.com>

➤ THREADED



Stepped

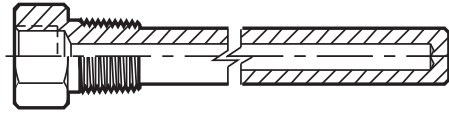

Straight

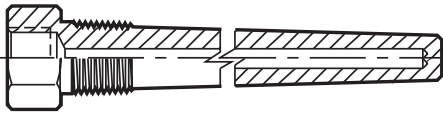

Tapered

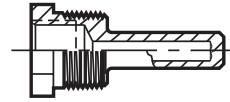

Limited Space

➤ FLANGED

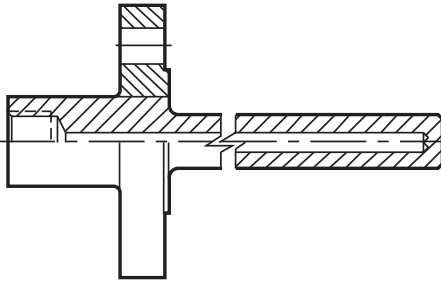

Straight

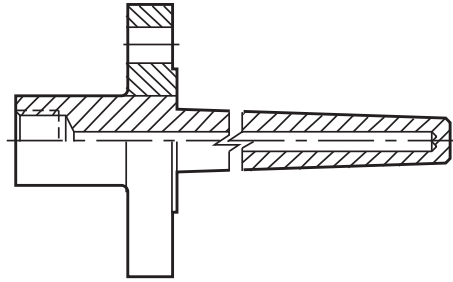

Heavy Duty Tapered

➤ WELDED

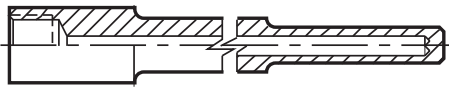

Socket Weld

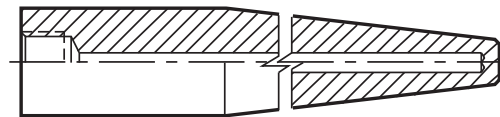

Weld-In

➤ SANITARY

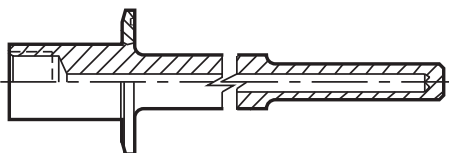

➤ VAN STONE

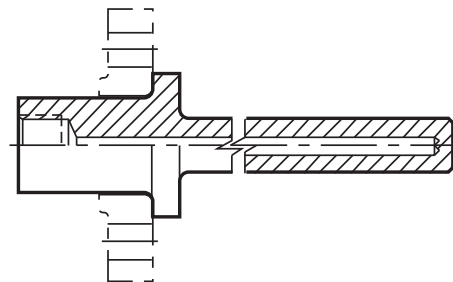

Special Configuration and Application Thermometers

Tel-Tru bimetal thermometers are manufactured in the USA.

► OEM THERMOMETERS

- Custom manufactured from standard or special components.
- Flexible in meeting custom requirements.
- Just-in-time delivery schedules.
- Quantities– one unit or thousands.
- Multiple option configurations available depending on model type, dial size, temperature range and applications.



OPTIONS:

- **Dials-Custom Imprinting** - Name, logo, zones, colors
- **Temperature Ranges** - Over 120 available (varies by dial sizes)
- **Accuracy** - As required for application
- **Stem Lengths** - Standards, intermediate, or extra short
- **Connections** - Plain, threaded, or special
- **Certificates** - Compliance, Accuracy etc.
- **Lens** - Standard or optional materials
- **Silicone Filled or Silicone Free**
- **Tagging**
- **Special Testing**

NOTE: Minimum quantities may be required for some options.

► HEAVY DUTY MARINE THERMOMETERS

STANDARD FEATURES

- Shock and vibration resistant.
- Stainless steel construction.
- Plastic lens.
- Anti-parallax dial for easy reading.
- External recalibration adjustment.
- Accurate to 1% of scale range when testing without well.
- Interchangeable with 5" scale size "submarine" thermometers having same stem length.
- 1/4" - 28 UN-2A union connection assembly **MUST** be used with thermowell or bushing.
- Does not comply with MIL I-17244E.

► BC-350R HD

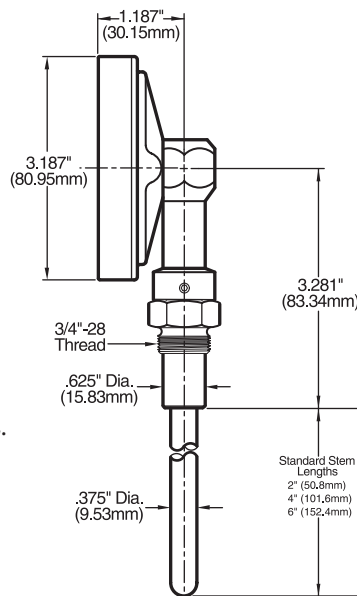

► GT-300R HD

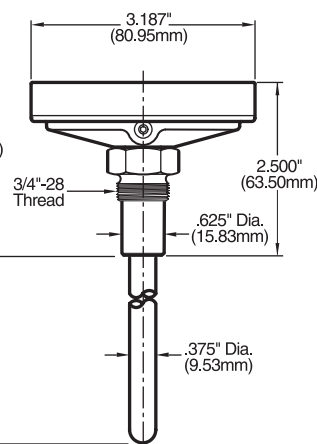

► THERMOWELL HD-MARINE

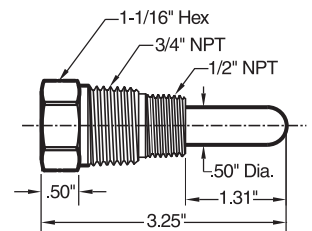



Tel-Tru® Manufacturing Company

408 St. Paul St., Rochester, New York 14605 USA

Phone: 585.232.1440 • 800.232.5335 • Fax: 585.232.3857 • E-mail: info@teltru.com • Web: www.teltru.com

► SILICONE FILLED THERMOMETERS



- Cases may be silicone filled for additional dampening of extreme vibration, or to assure consistent performance in low process temperature/high environmental humidity applications.
- Available on all 2", 3", 4" and 5" industrial thermometers and LT-225/LT-225R.
- Silicone filled thermometers are recommended for use with process temperatures ranging from a minimum of -50°F (-45°C) to a maximum of 500°F (260°C).
- Use of silicone fill should be avoided where strong oxidizing agents such as oxygen, chlorine, nitric acid, and hydrogen peroxide are present.

► THERMOMETERS WITH HEAVY DUTY POINTED STEMS AND DETACHABLE HANDLE



APPLICATIONS:

- Compost/Windrow Testing
- Soil/Asphalt Testing
- Meat Processing
- Mushroom Growing
- Can be used with 1/2" NPT connection.
- Stem diameter .250" or .375" (recommended).
- Stem diameter .375" with .250" tapered rod available.

► SANITARY BIMETAL THERMOMETERS



- Heavy duty thermometers meet 3A Standard Number 74-03
- Tri-Clamp® sanitary fittings are integral to the thermometers
- Constructed of 316L SS wetted parts and 304SS non-contact parts
- Configurations include back connected, bottom connected, and adjustable angle models in a variety of dial sizes and stem lengths
- Hermetically sealed per ASME B40.3
- Ideal for the dairy processing industry, as well as food and beverage processing and pharmaceutical industries

For additional specifications, go to www.teltru.com/s-59-sanitary-bimetal.aspx

Tri-Clamp is a registered trademark of Tri-Clover, Inc.

Special Application Thermometers

► GLOW DIAL AND REFLECTIVE THERMOMETERS

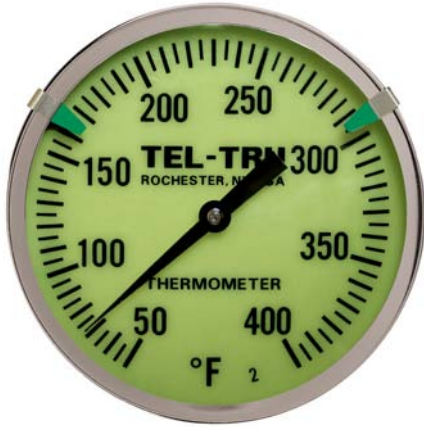

- 5" Adjustable Angle or Back Connect
- Glow dial is luminescent coated aluminum
- Aluminum Reflective Pointer
- Two 304SS Reflective Clips snap onto the dial rim. You decide where you want to set each reflective clip--minimum and maximum limits can be indicated, which allows for on the spot customization
- Glow dials also available on models AD-10R and AD-44R (without clips)

This remarkably easy solution permits anyone viewing the thermometer, up close in the light of day or far away at night, to easily see if the process is operating within a designated safe zone. The thermometer can be read from a distance in low light conditions; all you need is a flashlight!

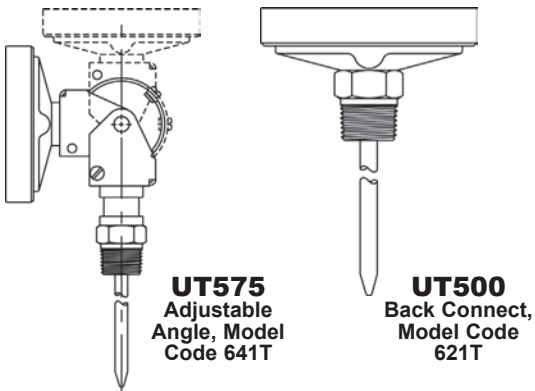

5" GLOW DIAL RANGES

Range	°/Div.	Code
0/250°F	2°	67
0/300°F	5°	57
0/500°F	5°	58
20/240°F	2°	59
50/300°F	2°	62
50/400°F	5°	63
50/500°F	5°	64
50/550°F	5°	68
150/750°F	10°	65
200/1000°F	10°	66
-50/120°F, -45/50°C	2°, 1°	25
-40/160°F, -40/70°C	2°, 1°	02
0/250°F, -20/120°C	2°, 2°	14
50/500°F, 0/250°C	5°, 2°	09
0/100°C	1°	76
0/150°C	1°	77
0/200°C	2°	78
0/250°C	2°	79



PT-50R
Glow dial option,
with 1" dial

For dimensions and ranges, see page 19.

For dimensions, see page 9 (UT575) or page 11 (UT500).

For additional specifications, go to www.teltru.com/s-16-glow-dial-reflective.aspx

► MINIMUM AND MAXIMUM THERMOMETERS

User can easily set red and/or blue lazy hands so that minimum and/or maximum temperatures reached by a process will be indicated.

- MM models indicate both maximum AND minimum.
- MX models indicate maximum OR minimum only.
- 3" dia. or 5" dia. back connected with recalibration feature.



MX-325R
(With 3" dial)

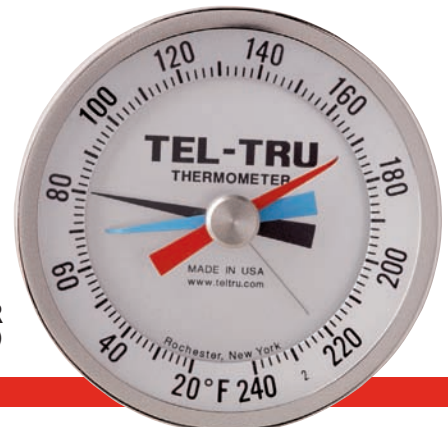

MM-525R
(With 5" dial)

Special Application Thermometers and Check-Set™ Thermometer Calibrators

► FOOD SERVICE THERMOMETERS

Tel-Tru offers a variety of NSF® approved Food Service Thermometers for Food/Beverage Processing, Food Service, Barbecue, Cooking, OEM Equipment and Retail.

APPLICATIONS

- Meat and Poultry Testing and Cooking
- Professional Food Testing
- Pocket Spot Check
- Gourmet
- Barbecue Pit and Grill
- Deep Fry/Candy

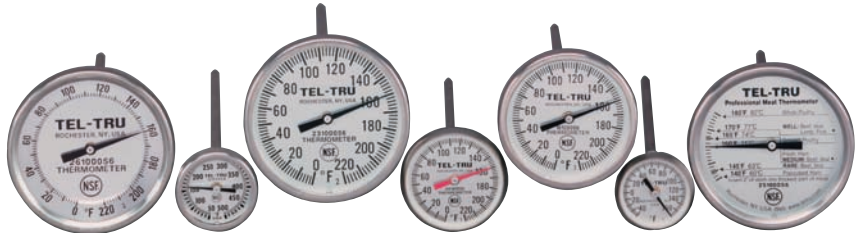

For additional specifications, go to
www.teltru.com/s-44-food-service.aspx

► CHECK-SET™ THERMOMETER CALIBRATORS

Environmental Safety and Health Professionals, Quality Assurance Managers and HACCP Coordinators in food processing/smoking, preparing/cooking, holding/serving and cooling/storage are using Check-Set Thermometer Calibrators to verify the accuracy of their dial and digital thermometers.

CHECK AND CALIBRATE AT YOUR CRITICAL TEMPERATURE POINT

- 40°F and 160°F / 5°C and 90°C - Dual cold and hot units.
- 40°F - Low temperature holding.
- 140°F - High temperature holding.
- 160°F - Temperature at which E. Coli and other pathogens are killed.
- 212°F - Point of boiling water
- Each unit serialized and certified traceable to the National Institute for Standards and Testing.
- Built in circuitry to warn if unit is more than 1°F out of calibration.
- Optional factory re-certification and maintenance program.



GENERAL CHECK-SET THERMOMETER CALIBRATOR SPECIFICATIONS:

- Accuracy: $\pm 0.2^{\circ}\text{F}$
- Stability: $\pm 0.06^{\circ}\text{F}$ to $\pm 0.09^{\circ}\text{F}$
- Heating Time: Approximately 3 – 8 minutes (varies with temperature set point)
- Stem Diameter: Up to .150"
- Voltage: 90 to 130 VAC, 50/60 Hz
- Power: 25 – 45 Watts
- Weight: 8.9 to 9.2 lbs.
- Housing Mat.: Stainless Steel 304SS
- Size: 3-1/16" H x 6-5/8" W x 10-7/8"D (78 mm x 168 x 276 mm)

NOTE: Other custom temperature models available

For additional specifications, go to www.teltru.com/s-46-calibrator.aspx

**Additional Products
available from Tel-Tru®**



Sanitary Bimetal Thermometers

Sanitary and Industrial RTDs

Sanitary and Industrial RTDs with Compact Transmitters

Glow Dial Thermometers

Digi-Tel Thermometers

Thermowells

HVAC Instruments

Gas Actuated Thermometers

Vapor Tension Thermometers

Thermometer Calibrators

Non-Contact Thermometers

Surface Thermometers

Pressure Transmitters

Pressure Gauges

Sanitary Pressure Gauges

Solar Digital Pressure Gauges



Tel-Tru is a registered trademark of Tel-Tru Manufacturing Co.

Tel-Tru® Manufacturing Company

408 St. Paul St., Rochester, New York 14605 USA

Phone: 585.232.1440 • 800.232.5335 • Fax: 585.232.3857

E-mail: info@teltru.com • Web: www.teltru.com